



Product Storage & Handling

The Channel Blender as shipped from the factory is crated and wrapped in plastic to protect from short term exposure to outdoor conditions while in transit. Long term storage should be in a dry location, or shipping crate tarped for longer term outside storage making sure the product is adequately protected from the elements.

The product is provided with four lifting points. Two lifting points on the sides are located approximately at the product's center-of-gravity axis. Additional eyelets can be used as shown to balance and steady the load when lifting. Use these lifting points as shown below to remove the Channel Blender from the shipping crate, transport to a manufacturing location, and/or positioning in a mixing box for mounting. These lifting points can also be used for support as necessary of the product in the mixing box. **Do not lift** the product by the damper blades, damper frame, or damper linkage.



Channel Blenders with horizontal blades for side entry mixing boxes are designed to sit on the floor of the AHU. There is a base that includes fork lift pockets to lift and move the unit.

Installation Information

Mixing Box Fit:

The Channel Blender is designed to be installed in the mixing box to align to OA and RA openings in the mixing box walls according to the selected orientation. The size and location of the openings are provided in product submittals for each unit.

Special Considerations for Retrofit Applications:

If the Channel Blender is being retrofit into an existing AHU, special considerations are needed. Specifically, the existing OA and RA dampers will need to be removed from the mixing box. The locations of the OA and RA openings may need to be relocated so that they align with Channel Blender. The size and location of the openings are provided in product submittals for each unit. Once the dampers have been removed and the openings correctly positioned, if there are any portions of the openings where



the AHU insulation is exposed this insulation should be covered and sealed in a way that prevents contact with the incoming airstreams.

Channel Blender Weights:

Most of the Channel Blender is constructed of light gauge aluminum and are relatively light for their physical size and volume. The typical Channel Blender will weigh less than 4 lbs./ft³ of volume or approximately .017 lb./CFM.

Mixing Box Installation:

The Channel Blender is designed to either “hang” from the wall and ceiling of the mixing box, or sit on the floor of the AHU plenum and secure to a wall or walls. Additional details and dimensions for the Channel Blender are provided with the Channel Blender submittal.

Hanging Installation:

When “hanging” from the wall and ceiling of the mixing box a 16Ga (minimum thickness) steel tube or c-channel frame construction should be located in the walls and ceiling of the mixing box panels to align with the mounting flanges provided with the Channel Blender (see below). A 1” wide polyurethane closed cell foam gasket or a heavy bead of 100% silicone should be placed on the surfaces of the Channel Blender that will mate and seal to the AHU walls and ceiling.

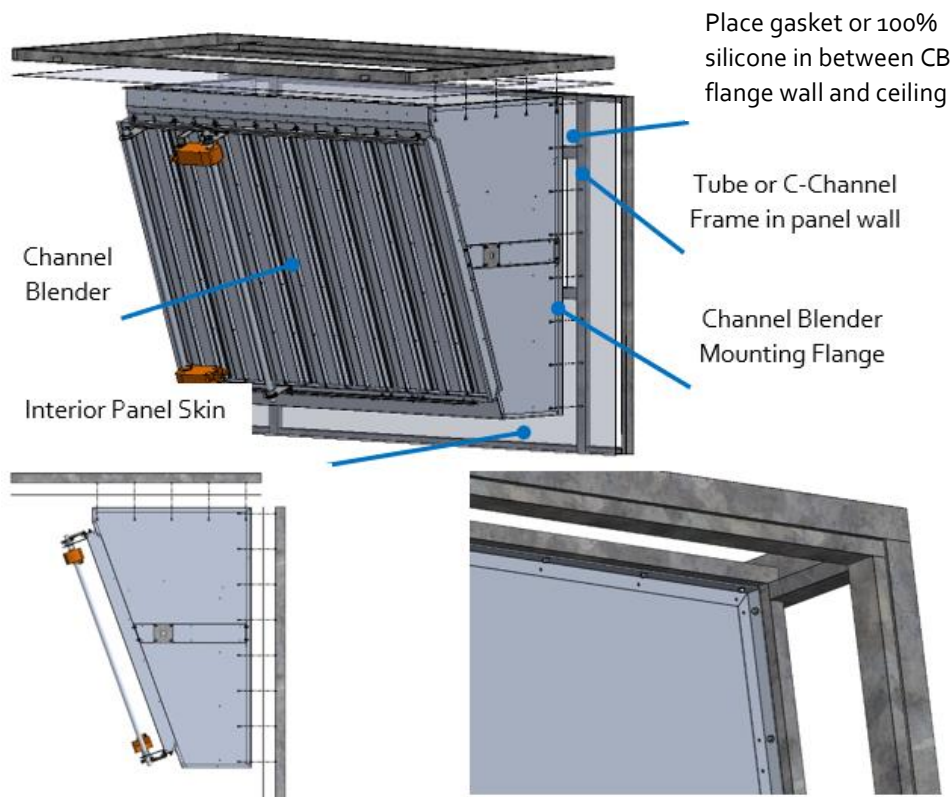



Fasteners should be selected to effectively carry the weight of the Channel Blender and compress the gasket to create a good seal. The Channel Blender is provided with .203" dia. holes in the mounting flanges every 5" to 8" (depending on span). The holes can accommodate #12-14 Tek screws. Each #12 Tek screw can hold 315 lbs. at a 3X safety factor for the metal thicknesses recommended.

Floor Installation:

Due to variations in height and depth of the Channel Blender based on the application and orientation, the load/ft² can vary from 15-50 lbs./ft². The floor of the mixing box must be designed to bear this load. Since the floor of the mixing box bears all the weight of the unit the fasteners are only used to secure the Channel Blender to the walls and compress the gasket or 100% silicone. As such no tube or c-channel frame construction is required in the walls or ceiling and screws securing the Channel Blender to the mixing box walls can simply fasten to the metal on the interior walls of the mixing box.

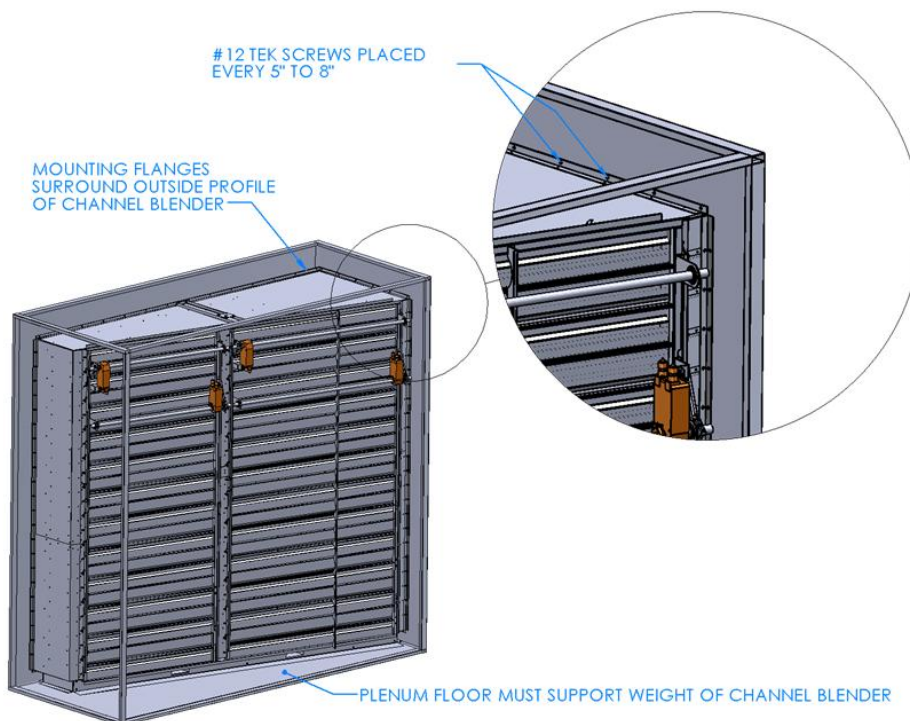

The installation method of the Channel Blender to an AHU OEMs mixing box can vary from OEM to OEM based size & weight of the Channel Blender and on the OEMs panel design.